

# WEST-TRANS

## SKIP LOADER

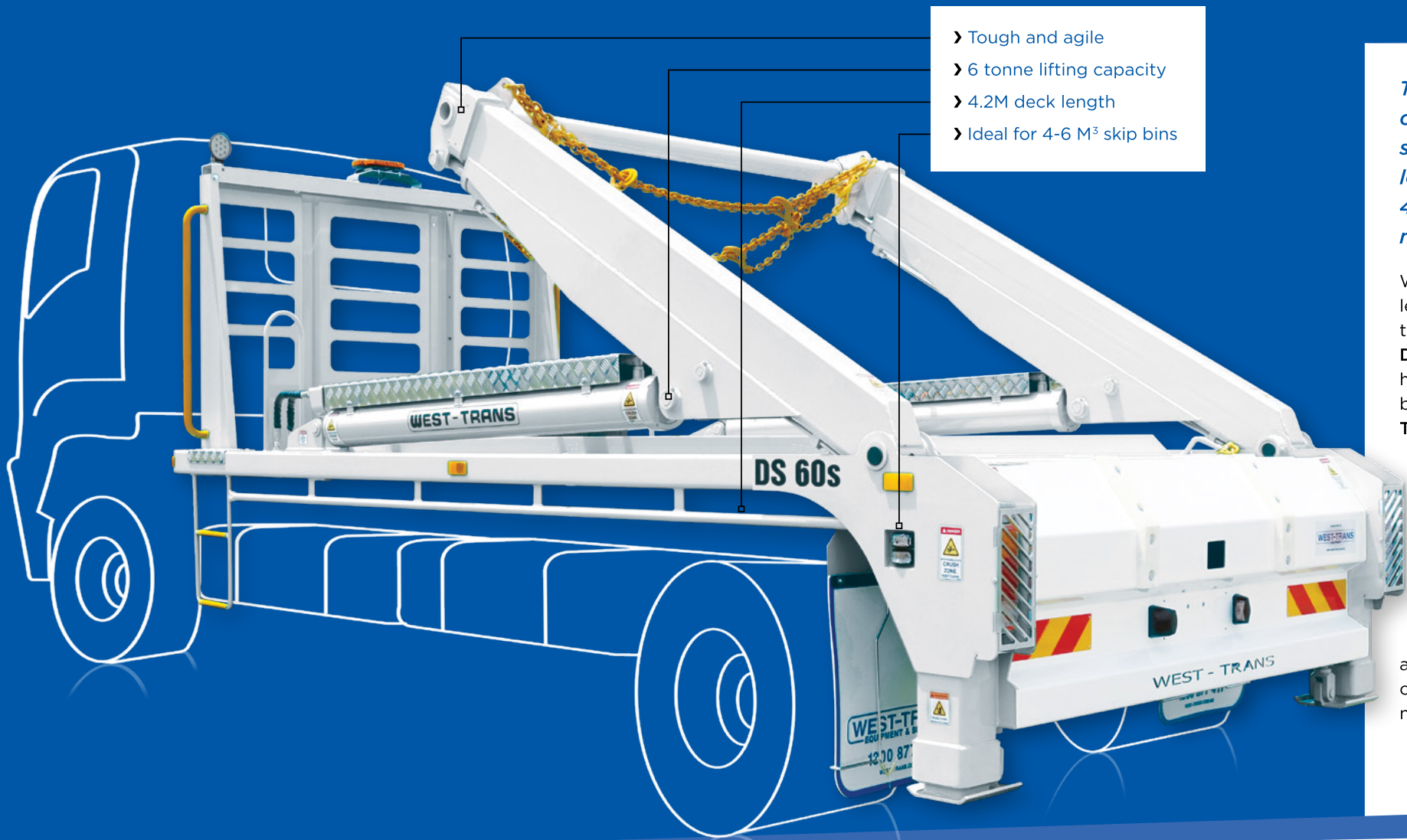

- › Tough and agile
- › 6 tonne lifting capacity
- › 4.2M deck length
- › Ideal for 4-6 M<sup>3</sup> skip bins

# DS 60s

## High Lift Capacity

*The West-Trans DS 60s, is the light middle-weight champion, ideal for inner city locations, and smaller suburban jobs. It has the toughness of the bigger loaders, in a more compact package. With a standard 4.2M deck, and optimised for fast turnaround, and nimble handling in compromised spaces.*

With the **West-Trans** industry leading engineered-in toughness and durability, the **DS 60s** is purpose built for handling 4 to 6 cubic meter bins. Like all of the **West-Trans** Skip and Hook loaders, it is craftsmen built in our factory in Mulgrave (NSW), from high quality parts and materials, and ready to work hard for years.

All **West-Trans** skip loaders can be recognised by their low arm fold height, aluminium cylinder protection, clean solid construction, and no fuss durability.

The arms on this middle-weight model fold down low, dealing with low clearance, and compromised access with ease.

Being designed and manufactured in Australia, they are, of course, built to meet or exceed all relevant Australia Design Rules, but more importantly, they are built to handle the toughest conditions Australia can through at them.

Speak to a **West-Trans** sales professional today, or go to the website [west-trans.com.au](http://west-trans.com.au) for more details.

Call 1300 877 411 or visit [west-trans.com.au](http://west-trans.com.au)

**WEST-TRANS**  
EQUIPMENT

## SKIP LOADER

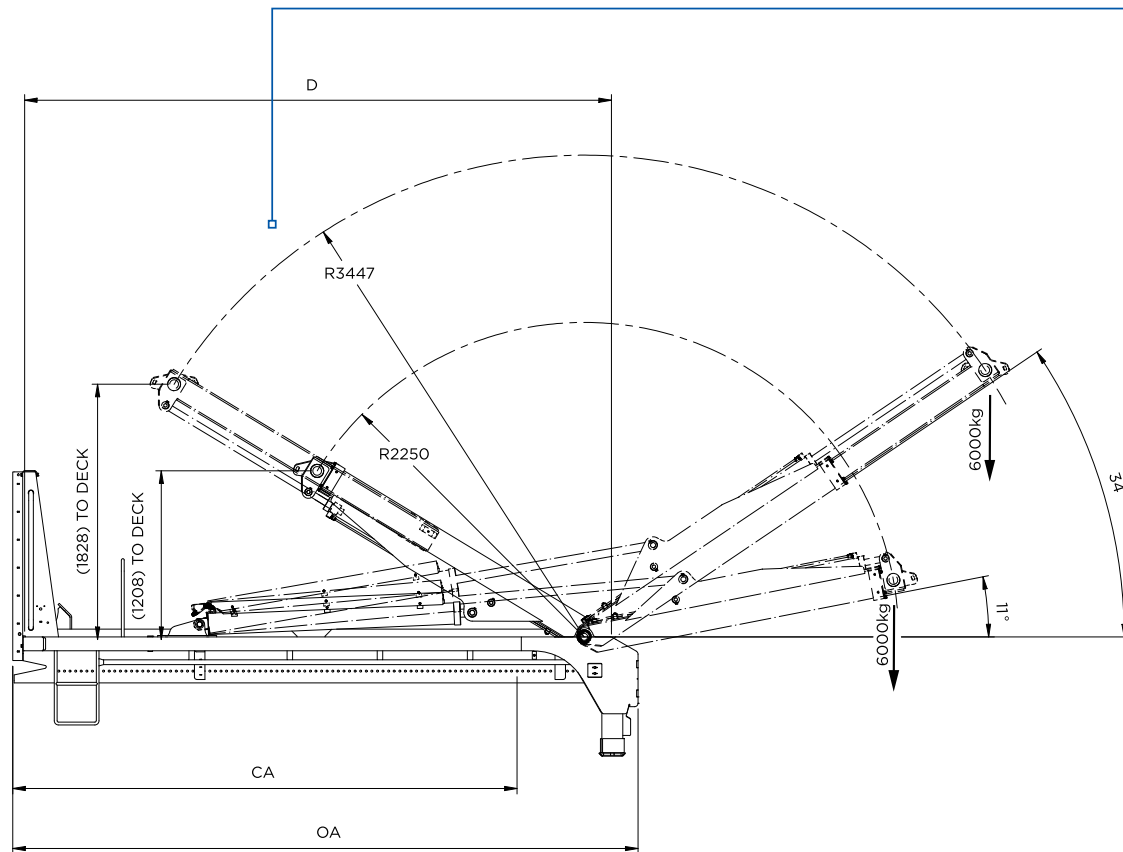

- > Side View
- > Rear View

D	CA	OA
4200	3600	4480
5100	4500	5380

Specifications subject to change

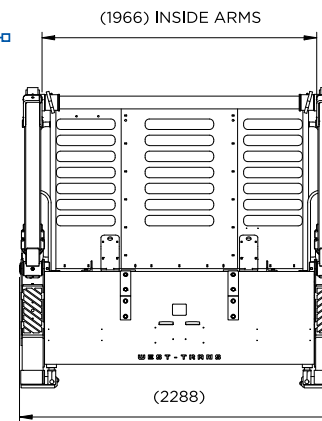

# DS 60s

## High Lift Capacity

This popular model is designed around the major truck manufacturer's standard single drive chassis in the 10,400-13,000kg GVM, MWB range and with a choice of 2 standard deck lengths available, most fitting without modification.

Of course, being built in Australia, you can choose a custom build, accommodating your choice of colour, or the addition of a range of accessories and modifications.

### Options:

- > Radio Remote Control
- > Additional tie down points
- > Amber Flashing Beacons
- > Tool Boxes
- > Work lights
- > Broom and Shovel Brackets
- > Tarping Systems
- > Special surface coatings
- > Extended deck options and designs available by special build

### Recommended Cab Chassis:

- > GVM 10,400-13,000kg
- > 4x2 4200mm wheel base (min 3600mm Cab to axle)

Choose a West-Trans skip loader. Built tough in Australia.