

# WEST-TRANS

## SKIP LOADER



- › Low in Tare weight, high in payload
- › 4 tonne lifting capacity
- › 3.85m deck length
- › Low folded arm height, ideal for tight access sites

# DS 40s

## High Lift Capacity

*The West-Trans DS 40s, is the small bin solution for tight building sites, inner city locations, and small suburban jobs. It is the small but tough answer to your problem. With a standard 3.85M deck, and optimised to low clearance and hard to get places, it is the loader of choice, when a larger truck just won't fit.*

With the **West-Trans** industry leading engineered-in toughness and durability, the **DS 40s** is purpose built for handling 2 to 4 cubic meter bins. Like all of the **West-Trans** Skip and Hook loaders, it is craftsmen built in our factory in Mulgrave (NSW), from high quality parts and materials, and ready to work hard for years.

All **West-Trans** skip loaders can be recognised by their low arm fold height, aluminium cylinder protection, clean solid construction, and no fuss durability. The arms on this compact model fold down low,

dealing with low clearance, tight construction spaces, and overhanging trees without trouble.

Being designed and manufactured in Australia, they are, of course, built to meet or exceed all relevant Australia Design Rules, but more importantly, they are built to handle the toughest conditions Australia can through at them.

Speak to a **West-Trans** sales professional today, or go to the website [west-trans.com.au](http://west-trans.com.au) for more details.

Call 1300 877 411 or visit [west-trans.com.au](http://west-trans.com.au)

**WEST-TRANS**  
EQUIPMENT

## SKIP LOADER

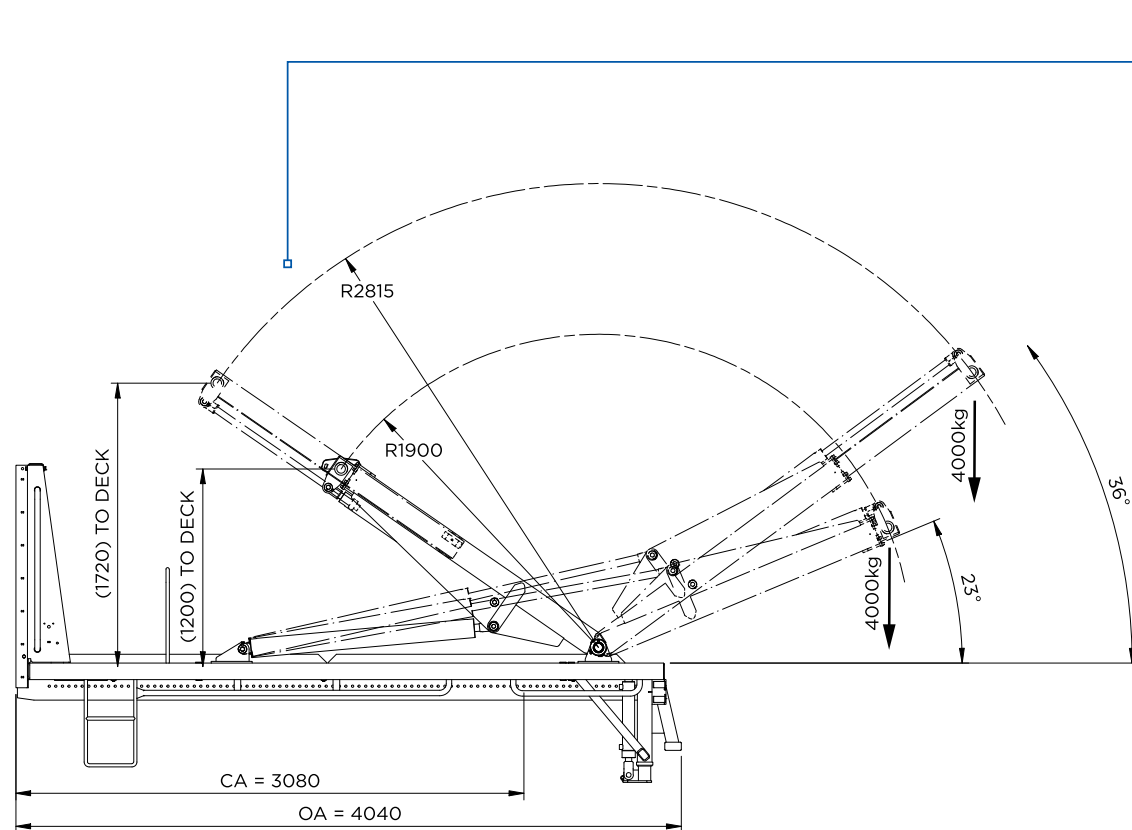

- > Side View
- > Rear View

D	CA	OA
3850	3850	4050

Specifications subject to change

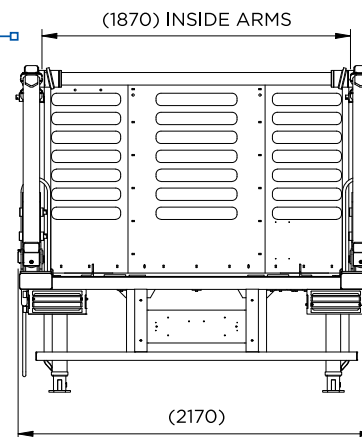

# DS 40s

## High Lift Capacity

*This popular model is designed around the major truck manufacturer's standard single drive chassis in the 7500-10,000kg GVM, MWB range and with a choice of 2 standard deck lengths available, most fitting without modification.*

Of course, being built in Australia, you can choose a custom build, accommodating your choice of colour, or the addition of a range of accessories and modifications.

### Recommended Cab Chassis:

- > GVM 7500-10,000kg
- > 4x2 3850mm wheel base (min 3850mm Cab to axle)

Choose a **West-Trans** skip loader.  
**Built tough in Australia.**

### Options:

- > Bi-Fold Arms
- > Radio Remote Control
- > Additional tie down points
- > Amber Flashing Beacons
- > Tool Boxes
- > Work lights
- > Broom and Shovel Brackets
- > Tarping Systems
- > Special surface coatings
- > Extended deck options and designs available by special build